

EXHIBIT A1

TOWN OF WATERBURY ZONING PERMIT APPLICATION

Date:	<u>02-26-2021</u>	Application #:	<u>009-21</u>
Fees Paid:	<u>267</u>	+ \$15 recording fee =	<u>282 -</u>
Parcel ID #:	<u>916-0143 V</u>		
Tax Map #:	<u>19-450.000</u>		

Please provide all of the information requested in this application.

Read the Zoning Regulations and familiarize yourself with the requirements. Failure to provide all the required information will delay the process of this application. Based upon the nature of the project you may need to submit additional information. For instructions on how to fill out this form please refer to the *Zoning Permit Application Instructions & Fee Schedule* available on the municipal website or at the municipal offices. Submit one copy of the completed application and a check payable to the *Town of Waterbury* according to the zoning fee schedule. For questions about the permit process, please contact the Zoning Administrator at 802-244-1018.

CONTACT INFORMATION

APPLICANT

Name: Lane Simon
 Mailing Address: 143 S Main Street
Waterbury Vermont 05676
 Home Phone : _____
 Work/Cell Phone: 802-793-2691
 Email: lane@simonop.com

PROPERTY OWNER (if different from Applicant)

Name: Phyllis Simon
 Mailing Address: 143 S Main Street
Waterbury Vermont 05676
 Home Phone : _____
 Work/Cell Phone: 802-793-2692
 Email: psimon@simonop.com

PROJECT DESCRIPTION

Physical location of project (E911 address): 143 S Main Street
Waterbury Vermont 05676
 Lot size: .19 Acres Zoning District: VMR / SFHA
 Existing Use: Office/Residential Proposed Use: Office/Residential
 Brief description of project: Removal of existing, deteriorated storage shed.
Replacement with storage area incorporated into additional on-site,
enclosed parking for the residence.

Cost of project: \$ 29,000 Estimated start date: 7/1/2021
 Water system: Public Waste water system: Public

EXISTING

Square footage: _____ Height: _____
 Number of bedrooms/baths: _____
 # of parking spaces: 5
 Setbacks: front: 4'
 sides: 39.5' / 5'6" rear: 43'4"

PROPOSED

Square footage: _____ Height: _____
 Number of bedrooms/bath: _____
 # of parking spaces: 8
 Setbacks: front: 4'
 sides: 39.5' / 5'6" rear: 6'5"

ADDITIONAL MUNICIPAL PERMITS REQUIRED:

- Curb Cut / Access permit E911 Address Request
 Water & Sewer Allocation none of the above

[Additional State Permits may also be required]

CHECK ALL THAT APPLY:

NEW CONSTRUCTION

- Single-Family Dwelling
- Two-Family Dwelling
- Multi-Family Dwelling
- Commercial / Industrial Building
- Residential Building Addition
- Comm./ Industrial Building Addition
- Accessory Structure (garage, shed)
- Accessory Apartment
- Porch / Deck / Fence / Pool / Ramp
- Development in SFHA (including repairs and renovation)
- Other _____

USE

- Establish new use
- Change existing use
- Expand existing use
- Establish home occupation

OTHER

- Subdivision (# of Lots: _____)
- Boundary Line Adjustment (BLA)
- Planned Unit Development (PUD)
- Parking Lot
- Soil/sand/gravel/mineral extraction
- Other _____

SKETCH PLAN

#009-21
SIMON

Please include a sketch of your project, drawn to scale, with all required measurements - see *Zoning Permit Application Instructions*. You may use the space below or attach separate sheets. For plans larger than 11"x17" please provide a digital copy (pdf. file format) in addition to a paper copy.

(see attached) EXHIBIT **A2**

SIGNATURES The undersigned hereby applies for a Zoning Permit for the use described in this application to be issued on the basis of the representations made herein all of which the applicant swears to be complete and true.

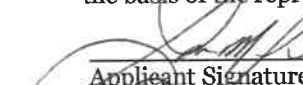
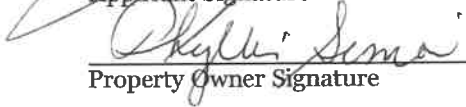
 Applicant Signature _____ date 2/26/21

 Property Owner Signature _____ date 2/26/21

CONTACT Zoning Administrator Phone: (802) 244-1018
 Mailing Address: Waterbury Municipal Offices, 28 North Main Street, Suite 1, Waterbury, VT 05676
 Municipal Website: www.waterburyvt.com

OFFICE USE ONLY

Zoning District/Overlay: Village Mixed-Residential (VMR)
 Review type: Administrative DRB Public Warning Required: Yes No
 DRB Referral Issued (effective 15-days later): _____
 DRB Mtg Date: _____ Decision Date: _____
 Date Permit issued (effective 16-days later): _____
 Final Plat due (for Subdivision only): _____
 Remarks & Conditions: _____

 Authorized signature: _____ Date: _____

REVIEW/APPLICATIONS:
 Conditional Use Waiver
 Site Plan
 Variance (lot coverage)
 Subdivision:
 Subdv. BLA PUD
 Overlay:
 DDR SFHA RHS CMP
 Sign
 Other _____
 n/a

EXHIBIT A3

Date:	<u>2/26/21</u>	Application #:	<u>009-21</u>
Fees Paid:	<input checked="" type="checkbox"/>	(\$15 recording fee already paid)	
Parcel ID #:			
Tax Map #:	<u>19-450.000</u>		

143 S. MAIN ST.

TOWN OF WATERBURY SITE PLAN REVIEW INFORMATION

This Site Plan Review information sheet supplements the Zoning Permit Application. Please provide all of the information requested on both forms. Read the Zoning Regulations and familiarize yourself with the requirements. Failure to provide all the required information will delay the process. Submit one copy of the completed forms and a check payable to the *Town of Waterbury* according to the zoning fee schedule. For questions about the permit process please contact the Zoning Administrator at 802-244-1018.

PROJECT DESCRIPTION

Brief description of project: Removal of existing, deteriorated storage shed.
Replacement with storage area incorporated into additional on-site, enclosed parking for the residence.

SITE PLAN REVIEW CRITERIA

Please utilize the check list to ensure your proposal addresses each relevant Site Plan Review criteria:

- Adequacy of traffic access
- Adequacy of circulation and parking
- Adequacy of landscaping and screening (including exterior lighting)
- Requirements for the Route 100 Zoning District
- Special considerations for projects bordering Route 2, Route 100, or Interstate 89

SITE PLAN SUBMISSION REQUIREMENTS

Before an application for site plan review is considered complete, the applicant shall file a site plan, clearly drawn to the largest practical scale, showing the following:

- Location and dimensions of lot lines, names of adjacent landowners, all easements, utilities, and existing and proposed structures.
- All access to public streets or roads, parking and service areas, pedestrian walkways, curbs and stormwater drainage.
- Pedestrian and vehicular circulation, including parking lot layout, entrances to structures, signs, and lighting.
- Building elevations and footprints.
- Detailed site grading and landscaping, indicating existing and proposed trees, shrubs, and ground cover.
- Two copies of all plans.
- For plans larger than 11"x17" please submit a digital plan set in addition to the paper copy (pdf. file format).

CONTACT Zoning Administrator Phone: (802) 244-1018
Mailing Address: Waterbury Municipal Offices, 28 North Main Street, Suite 1, Waterbury, VT 05676
Municipal Website: www.waterburyvt.com

EXHIBIT A4

TOWN OF WATERBURY CONDITIONAL USE INFORMATION

This Conditional Use (and Setback Waiver) information sheet supplements the Zoning Permit application. Please provide all of the information requested on each form. Read the Zoning Regulations and familiarize yourself with the requirements. Failure to provide all the required information will delay the process. Submit one copy of the completed forms and a check payable to the *Town of Waterbury* according to the zoning fee schedule. For questions about the permit process, please contact the Zoning Administrator at 802-244-1018.

Date:	<u>2/26/21</u>	Application #:	<u>009-21</u>
Fees Paid:	<input checked="" type="checkbox"/>	(\$15 recording fee already paid)	
Parcel ID #:			
Tax Map #:	<u>19-450.000</u>		

143 S. MAIN ST. / SIMON

PROJECT DESCRIPTION

Brief description of project: Removal of an attached, deteriorating storage structure at the rear of the building.

Replacement of that structure with an attached, 3 bay garage to the existing structure.

CONDITIONAL USE CRITERIA

Please respond to the following; you may answer on a separate sheet and attach additional pages and supporting materials:

1. Describe how the proposed use will not have an undue adverse impact on the capacity of existing or planned community facilities to accommodate it (including roads and highways, municipal water or sewer systems, school system, fire protection services): There will be no adverse affects as this is just an improvement of onsite parking and storage. There will be no additional traffic to the site or increased occupation of the property.
2. Describe how the proposed use will not have an undue adverse impact on the character of the area affected as defined by the Municipal Plan and the zoning district in which the proposed project is located: The proposed addition will be added to the rear of the existing. It will have little to no visual impact on the front of the property along Main Street.
3. Describe how the proposed use will not violate any municipal bylaws and ordinances in effect:
There will be no change in use.
4. Describe any devices or methods to prevent or control fumes, gas, dust, smoke, odor, noise, or vibration:
Not applicable.
5. For removal of earth or mineral products which is not incidental to a construction, landscaping, or agricultural operation, a removal project must meet specific conditions outlined within Section 302 of the Waterbury Zoning Regulations. Are the conditions included within the Application Submittals?
Not applicable

CONTACT Zoning Administrator Phone: (802) 244-1018
Mailing Address: Waterbury Municipal Offices, 28 North Main Street, Waterbury, VT 05676
Municipal Website: www.waterburyvt.com

EXHIBIT A5

Date:	<u>2/26/21</u>	Application #:	<u>009-21</u>
Fees Paid:	<input checked="" type="checkbox"/>	(\$15 recording fee already paid)	
Parcel ID #:	_____		
Tax Map #:	<u>19-450.000</u>		

143 S. MAIN ST.

TOWN OF WATERBURY VARIANCE INFORMATION

This Variance information sheet supplements the Zoning Permit Application. Please provide all of the information requested on both forms. Read the Zoning Regulations and familiarize yourself with the requirements. Failure to provide all the required information will delay the process. For questions about the permit process please contact the Zoning Administrator at 802-244-1018.

1) What type of Variance are you requesting? Setback and coverage variance.

2) Describe the unique physical circumstances or conditions, including irregularity, narrowness, or shallowness of lot size or shape, or exceptional topographical or other physical conditions peculiar to the particular property, that prevent development occurring in strict compliance with the zoning regulations (Please include relevant site features on the Sketch Plan with the accompanying Zoning Permit Application) . _____

The lot dimensions, overall size and existing setbacks are currently non-conforming to the VMR requirements. This limits any improvements to the property.

3) Describe why the development is necessary to enable the reasonable use of the property.

The existing storage is deteriorating and is necessary for safe, secure storage of business supplies and equipment.

There is no covered parking on site. We would like to address both of these items by replacing the shed and adding the enclosed parking for the residence/office on the back of the existing structure.

4) What hardship will result if the variance is not granted? Possible damage to vehicles, equipment and supplies.

The existing roof is quite steep and metal. Snow sliding off the roof limits where vehicles can be safely parked.

5) Describe how the proposed development will compliment the essential character of the neighborhood. _____

There are numerous mixed use and residential properties with storage sheds & garages in the immediate vicinity.

We foresee no change in character to the neighborhood. The addition will be minimally visible from the street, if at all.

Construction will be consistent with the current structure and should have no visual impact to neighbors.

6) Describe how the development will not permanently impair the appropriate use or development of adjacent property, reduce access to renewable energy resources, or be detrimental to the public welfare. _____

There does not appear to be any impact to adjacent properties. There is no common access or shared use with neighboring lots. We are requesting the ability to work within the existing setbacks to improve the property for the current uses.

EXHIBIT A6

Date:	<u>2/26/21</u>	Application #:	<u>009-21</u>
Fees Paid:	<input checked="" type="checkbox"/>	(\$15 recording fee already paid)	
Parcel ID #:	_____		
Tax Map #:	<u>19-450.000</u>		

143 S. MAIN ST.

TOWN OF WATERBURY OVERLAY DISTRICT INFORMATION

This Overlay District information sheet supplements the Zoning Permit Application. Please provide all of the information requested on both forms. Read the Zoning Regulations and familiarize yourself with the requirements. Failure to provide all the required information will delay the process. Submit one copy of the completed forms and a check payable to the *Town of Waterbury* according to the zoning fee schedule. For questions about the permit process please contact the Zoning Administrator at 244-1018.

PROJECT DESCRIPTION

Brief description of project: Removal of an attached, deteriorating storage shed at the rear of the building.

Replacement with storage area incorporated into additional on-site, enclosed parking for the residence.

Fill out only the relevant section(s) & utilize the following checklists to ensure your plans include all the required information.

DOWNTOWN DESIGN REVIEW OVERLAY DISTRICT (DDR)

DESIGN STANDARDS:

For Historic Structures (applying to all structures listed on the National Register of Historic Places):

- Original materials or materials typical of the architectural style are preserved or replaced with like materials to the extent feasible and appropriate.
- Historic building features shall be preserved or replicated to the extent feasible and appropriate.

For projects within the Historic/Commercial Sub-District:

- New building designs shall reinforce historic streetscape patterns, including orientation and setbacks.
- New buildings shall maintain overall height, size, massing, scale, and proportions compatible with those of buildings in the vicinity.
- New additions are designed to complement and be compatible with the original structure.
- Project design reinforces a pedestrian streetscape.
- On-site utilities shall be buried and utility boxes are screened from public view if the utilities along the street serving that structure are also buried.
- Buildings, or portions thereof, having eaves heights of 20-foot or less above ground level incorporate moderately to steeply pitched roofs, unless the another roof type is appropriate.

For projects within the Mixed-Use Sub-District:

- Building sites, including road and pedestrian networks, are designed in a manner that is integrated and compatible with adjoining parcels and areas.
- A proposed project located next to or facing a historic structure incorporates similar or complementary building features.
- New buildings are oriented to front upon, and relate both functionally and visually to, primary access roads.
- On-site parking is situated to the rear or on the sides of structures, where feasible and appropriate.
- The primary facades of principal structures are clearly defined through the placement of one or more prominent entryways, pedestrian walkways, or landscaping features.
- Building facades and rooflines are designed so as to reduce the perceived mass, scale, and uniform impersonal appearance of large buildings and additions, and to provide visual interest.
- Clearly defined pedestrian walkways are provided through parking areas, between buildings, and from public sidewalks to the site.

SUBMISSION REQUIREMENTS:

- All information required under Site Plan (see Site Plan Application)
- Proposed architectural elevations (for each exterior wall) showing door and window types and placement, and other exterior details
- A description of all materials to be used on the exterior of building
- Photos of the existing building(s) on the site and adjacent and facing parcels
- For demolition of a structure listed on the National Register of Historic Places see additional requirements within the Regulations.

RIDGELINE, HILLSIDE, STEEP SLOPE OVERLAY DISTRICT (RHS)

REVIEW STANDARDS:

- For both Minor & Major Development Projects see Conditional Use Criteria
- For Major Development Projects:
 - Screening
 - Access
 - Placement of Structures
 - Exterior Lighting
 - Clearcutting and Pre-Development Site Preparation
 - Natural Resources
 - Building Design

SUBMISSION REQUIREMENTS :

- Minor Development Projects (1,200—1,499 FIE)
 - All information required under Site Plan Review (see Site Plan Review Application)
 - Completed Conditional Use Application
- Major Development Projects (1,500 & up FIE)
 - All information required under Site Plan Review (see Site Plan Review Application)
 - Completed Conditional Use Application
 - Grading Plan
 - Visibility Studies
 - Stormwater Drainage/Erosion Control Plan
 - Landscape Plan
 - Access Plan Natural Features

SPECIAL FLOOD HAZARD AREA OVERLAY DISTRICT (SFHA)

DESIGN STANDARDS:

- All development is reasonably safe from flooding All fuel storage tanks are either elevated or floodproofed.
- All substantial improvements and new construction (including fuel storage tanks) meet the following criteria:
 - Designed, operated, maintained, modified and adequately anchored to prevent flotation, collapse, release, or lateral movement of the structure
 - Constructed with materials resistant to flood damage
 - Constructed by methods and practices that minimize flood damage
 - Constructed with electrical, heating, ventilation, plumbing and air-conditioning equipment and other service facilities that are designed and/or located so as to prevent water from entering or accumulating within the components during conditions of flooding
 - All new subdivisions and other proposed developments that are greater than 50 lots or 5 acres, whichever is the lesser shall include within such proposal base flood elevation data. See Regulations for additional subdivision standards.
 - The fully enclosed areas below the lowest floor that are useable solely for parking of vehicles, building access, or storage in an area other than a basement are designed to automatically equalize hydrostatic flood forces on exterior walls by allowing for the entry and exit of floodwaters.
 - A non-residential, appurtenant structure of 500 sf or less need not be elevated to or above the base flood elevation in this area, provided the structure is placed on the building site so as to offer the minimum resistance to the flow of floodwaters
 - In Zones AE, A, and A1 – A30 where base flood elevations and/or floodway limits have not been determined, new construction and substantial improvement shall not be permitted unless it is demonstrates additional standards (see Regulations)
 - All new construction and substantial improvements of residential structures within Zones A1-30, and AE must have the lowest floor of all residential structures (including basement) elevated to at least one foot above the base flood level.
 - All manufactured homes are installed using methods and practices which minimize flood damage. Manufactured homes must be elevated on a permanent foundation such that the lowest floor of the manufactured home is at least one foot above base flood elevation, and they must be anchored to an adequately anchored foundation to resist flotation collapse, or lateral movement.
 - All new construction and substantial improvements of non-residential structures within Zones A1-30, and AE shall:
 - Have the lowest floor (including basement) elevated to at least two feet above the base flood level; or
 - Be designed so that below the base flood level the structure is water tight with walls substantially impermeable to the passage of water with structural components having the capability of resisting hydrostatic and hydrodynamic loads and

effects of buoyancy to a point at least two feet above the base flood level.

- Where a non-residential structure is intended to be made watertight below the base flood level a registered professional engineer or architect shall develop and/or review structural design
- Adequate drainage paths shall be required around structures on slopes to guide floodwaters around and away from proposed structures.
- ___ The flood carrying and sediment transport capacity within the altered or relocated portion of any watercourse shall be maintained, and any alteration or relocation shall not result in any decrease of stream stability.
- ___ Bridge and culverts, which by their nature must be placed in or over the stream, must obtain a stream alteration permit from the Agency of Natural Resources, if required.

SUBMISSION REQUIREMENTS:

- Plans in triplicate, drawn to scale, showing the location, dimensions, contours, and elevation of the lot; the size and location on the site of existing or proposed structures, fill or storage of materials; the location and elevations of streets, water supply, and sanitary facilities; and the relation of the above to the location of the channel, floodway, and base flood elevation
- Specifications for building construction and materials, floodproofing, mining, dredging, filling, grading, paving, excavation, or drilling, channel improvement, storage of materials, water supply, and sanitary facilities
- Base flood elevation data for all subdivisions, new construction, and substantial improvements
- The elevation, in relation to mean sea level, of the lowest floor, including basement, of all new construction or substantial improvement of structures
- Where floodproofing is used in lieu of elevation, the elevation, in relation to mean sea level, to which any structure or substantial improvement will be floodproofed
- Where an application requires Board review the application shall include certification by a registered professional engineer or architect demonstrating that the proposed development will not increase base flood elevations more than 0.25 foot
- Certification by a registered professional engineer or architect demonstrating compliance with the elevation requirements
- A description of the extent to which any watercourse will be altered or relocated as a result of the proposed development
- A Vermont Agency of Natural Resources Project Review Sheet for the proposal
- Proposed floodproofing must be supported by a FEMA Floodproofing Certificate

CERTIFICATE OF COMPLETION: Upon completing the project the Applicant must apply for and receive a Certificate of Completion to ensure the project conforms to the Special Flood Hazard Area Regulations. See Certificate of Completion Application for additional information.

CONTACT Zoning Administrator Phone: (802) 244-1018
 Mailing address: Waterbury Municipal Offices, 28 North Main Street, Suite 1, Waterbury, VT 05676
 Municipal Website: www.waterburyvt.com

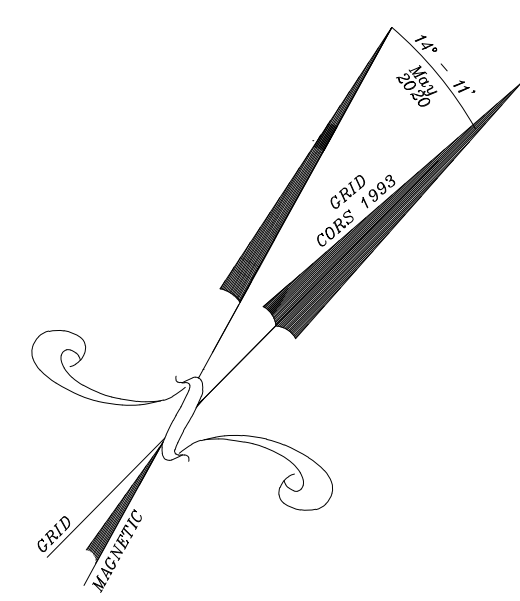

LEGEND

- TP-1 Traverse point
- IPF Iron pipe found
- AIF Angle iron found
- Water shut off valve
- Sewer manhole
- Catch basin
- Tree
- Fence
- 100' 5' contours
- 1' contours
- Property line
- Hedge row

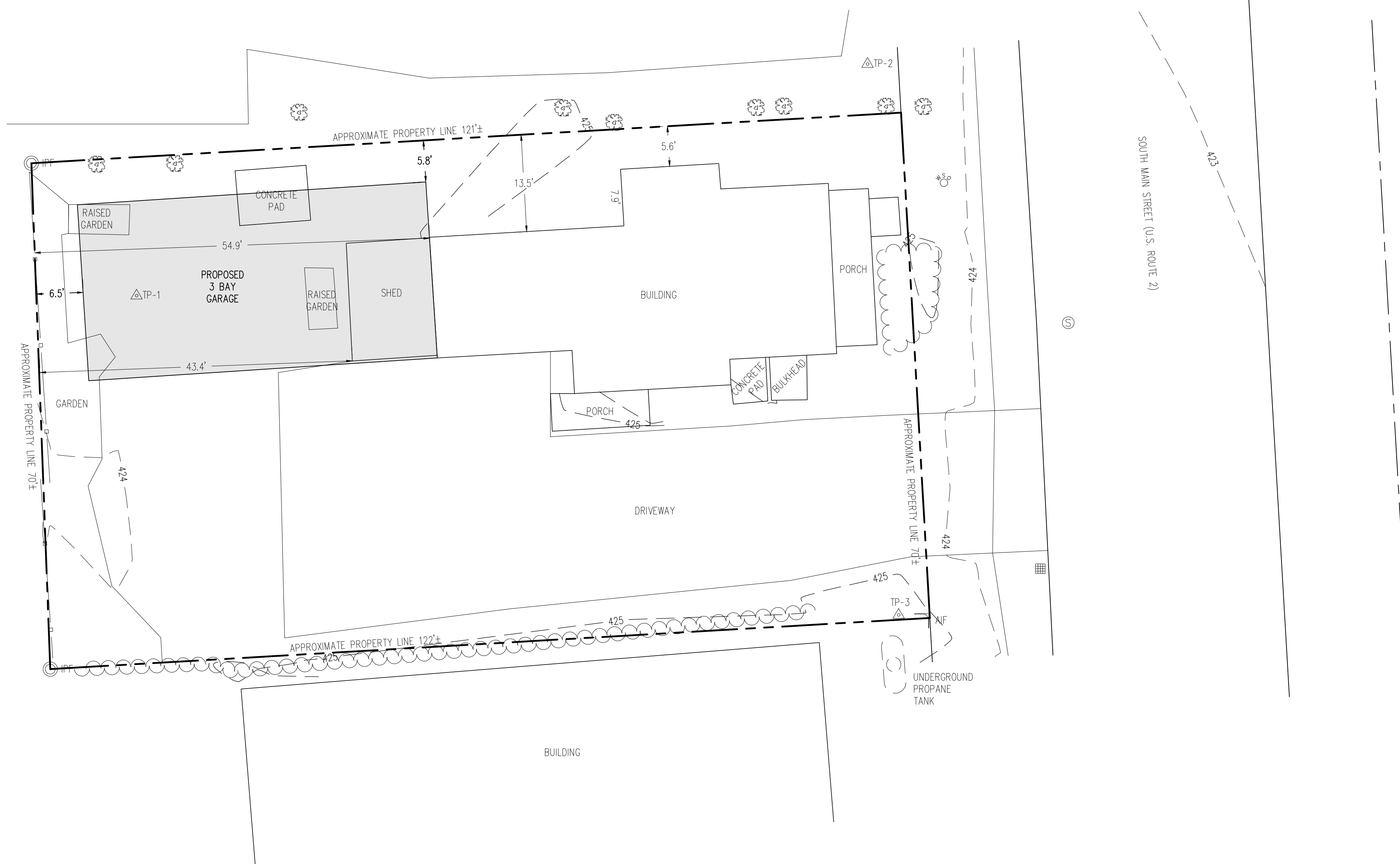

- Notes:**
1. Property is in Flood Zone AE, with a Base Flood Elevation of 427.2'. The entire property is in the Special Flood Hazard Area.
 2. Parcel ID: 916-0143V
 3. Current Title: in Book 265, Page 611 of the Waterbury Land Records.
 4. The property is described as being 4 rods (66') wide by 8 rods (132') deep per Book 29, Page 237 of the Waterbury Land Records. No mention of any property markers was made in the description, however the iron pipes on the west side of the parcel appear that they are being relied on as the boundary markers. As a result of this, the more specific occupation evidence is being shown as the boundary lines as compared to the general deed description.

Setbacks:
 The following are general setback distances that must be met unless otherwise authorized by the permitting authority and/or the consultant. This list does not necessarily include all required setback distances and the listed setback distances may not apply to all sites:

ITEM	LEACHFIELD	SEPTIC TANK	SEWER
DRILLED WELL	SEE PLAN	50	50
SPRING	SEE PLAN	75	75
LAKES, PONDS, IMPOUNDMENTS	50	25	25
RIVERS, STREAMS	50	25	10
PROPERTY LINE	25	10	10
ROADWAY, DRIVEWAY, PARKING LOTS	10	5	SEE PLAN
TREES	10	10	10
SERVICE WATER LINE	25	25	SEE PLAN

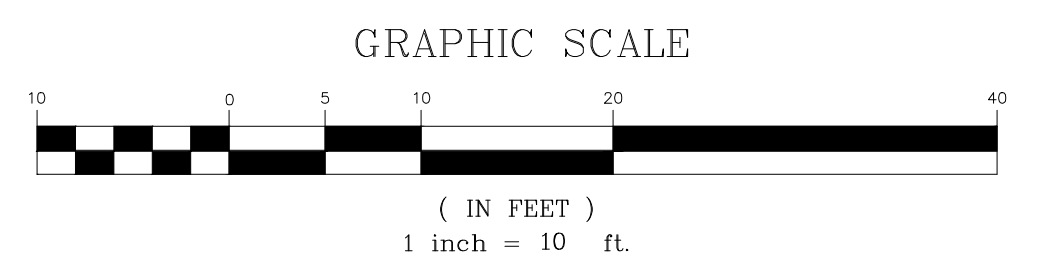

Topography by Total Station
 Contour Interval 1'
 Datum NAVD 88

THE CONTRACTOR SHALL REVIEW ALL CONSTRUCTION ACTIVITIES, COMPONENT LOCATIONS, SPECIFICATIONS, AND DETAILS PRIOR TO COMMENCEMENT OF SITE WORK AND SHALL NOTIFY MCCAIN CONSULTING OF ANY ISSUES OR DISCREPANCIES THAT ARISE FROM THAT REVIEW.

THIS IS NOT A SURVEY. THIS PLAN DOES NOT MEET THE REQUIREMENTS OF 27 VSA SEC. 1403 FOR THE FILING OF SURVEY PLATS.

EXHIBIT B

#009-21 SIMON 2/26/21

SITE PLAN
PHYLLIS SIMON

143 SOUTH MAIN STREET WATERBURY, VT

SCALE : 1" = 30'
 DESIGNED BY: PROJECT #40025
 DRAWN BY: SJH
 CHECKED BY: KV

MCCAIN CONSULTING, INC.
 93 SOUTH MAIN STREET
 WATERBURY, VERMONT 05676

DATE: July 1, 2020 SHEET 1 OF 1

8.4.20

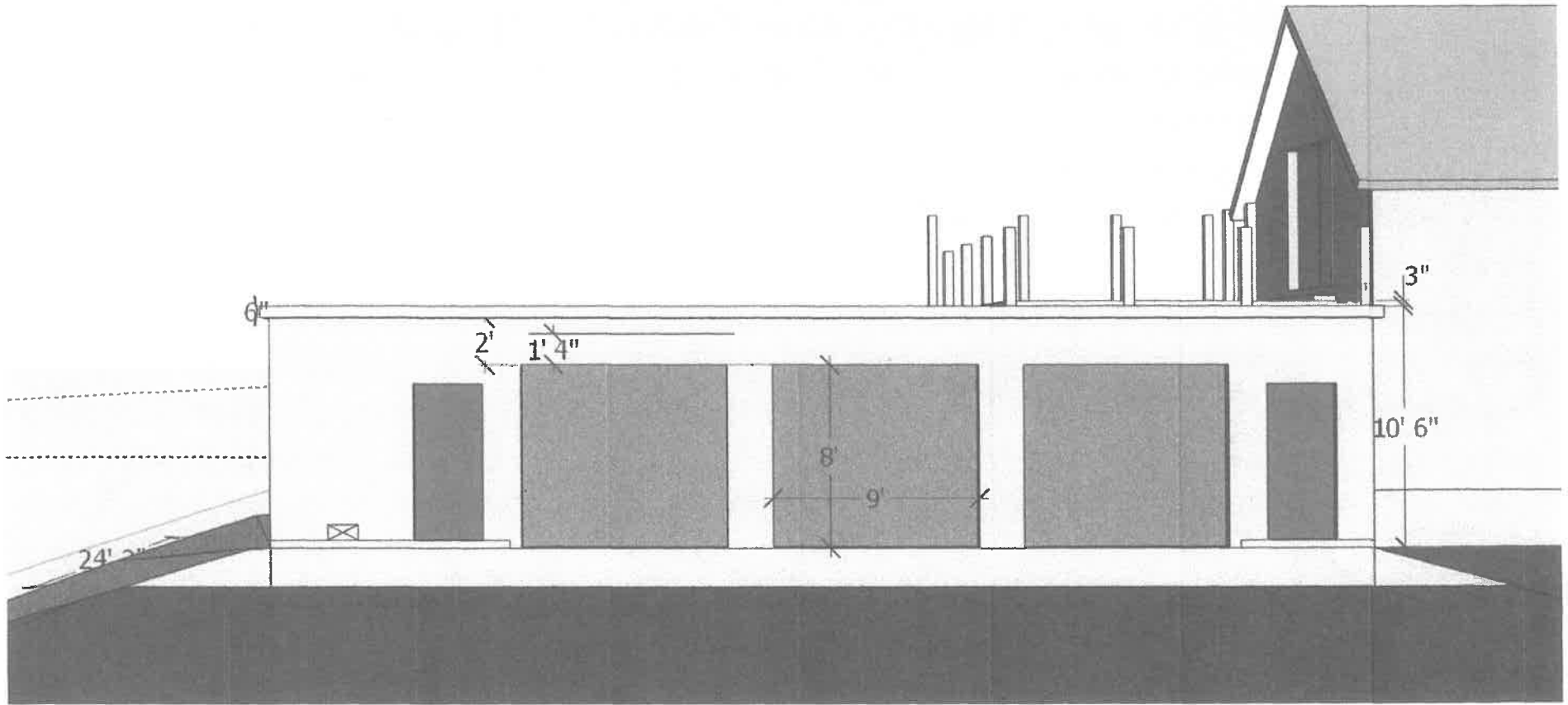

EXHIBIT C1

#009-21
SIMON
2/26/21

#096-20
SIMON
8/20/20

South A (Facing 145 S. Main St, NAPA Auto Parts)

143 S. MAIN ST. WATERBURY

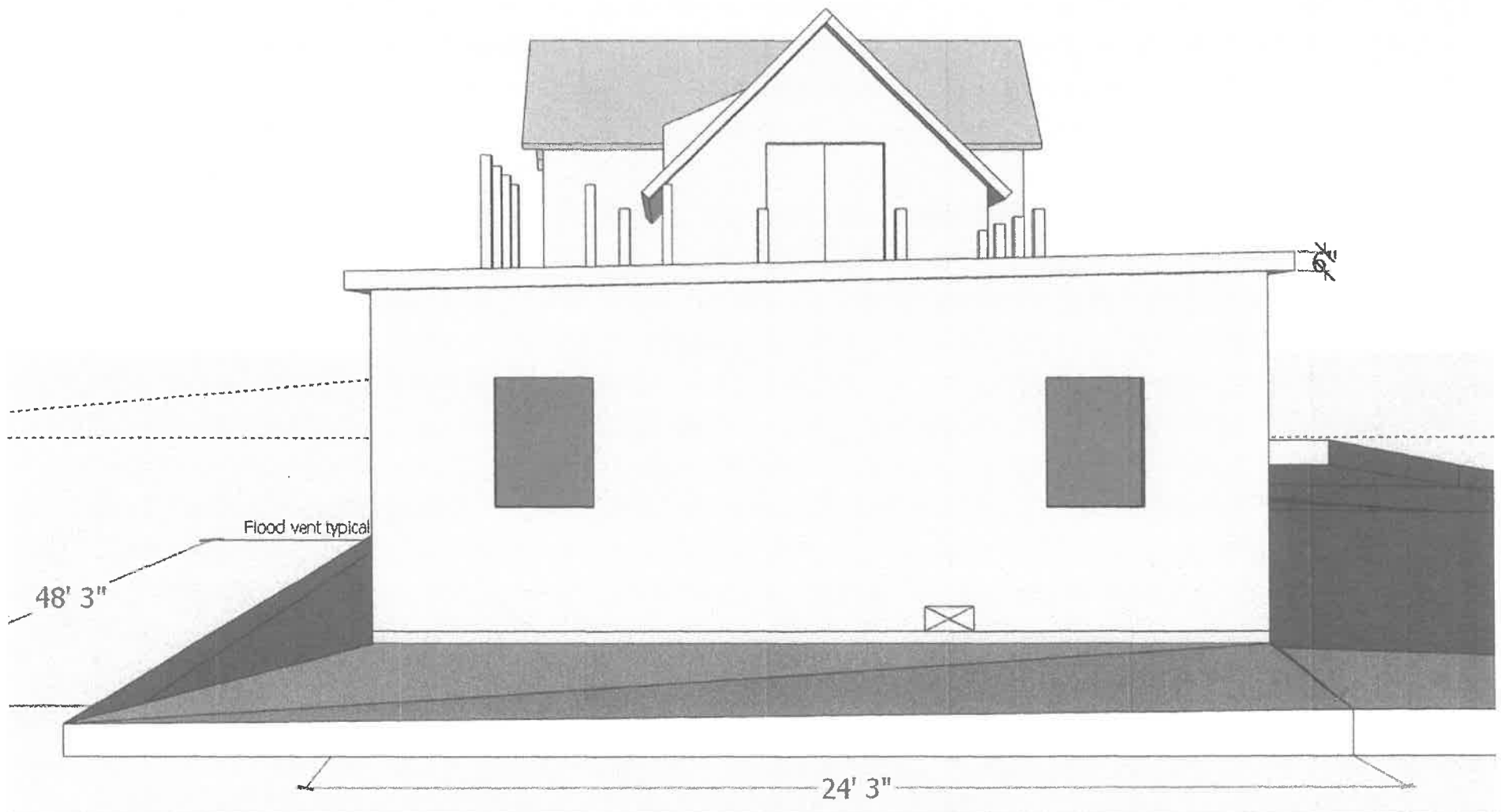
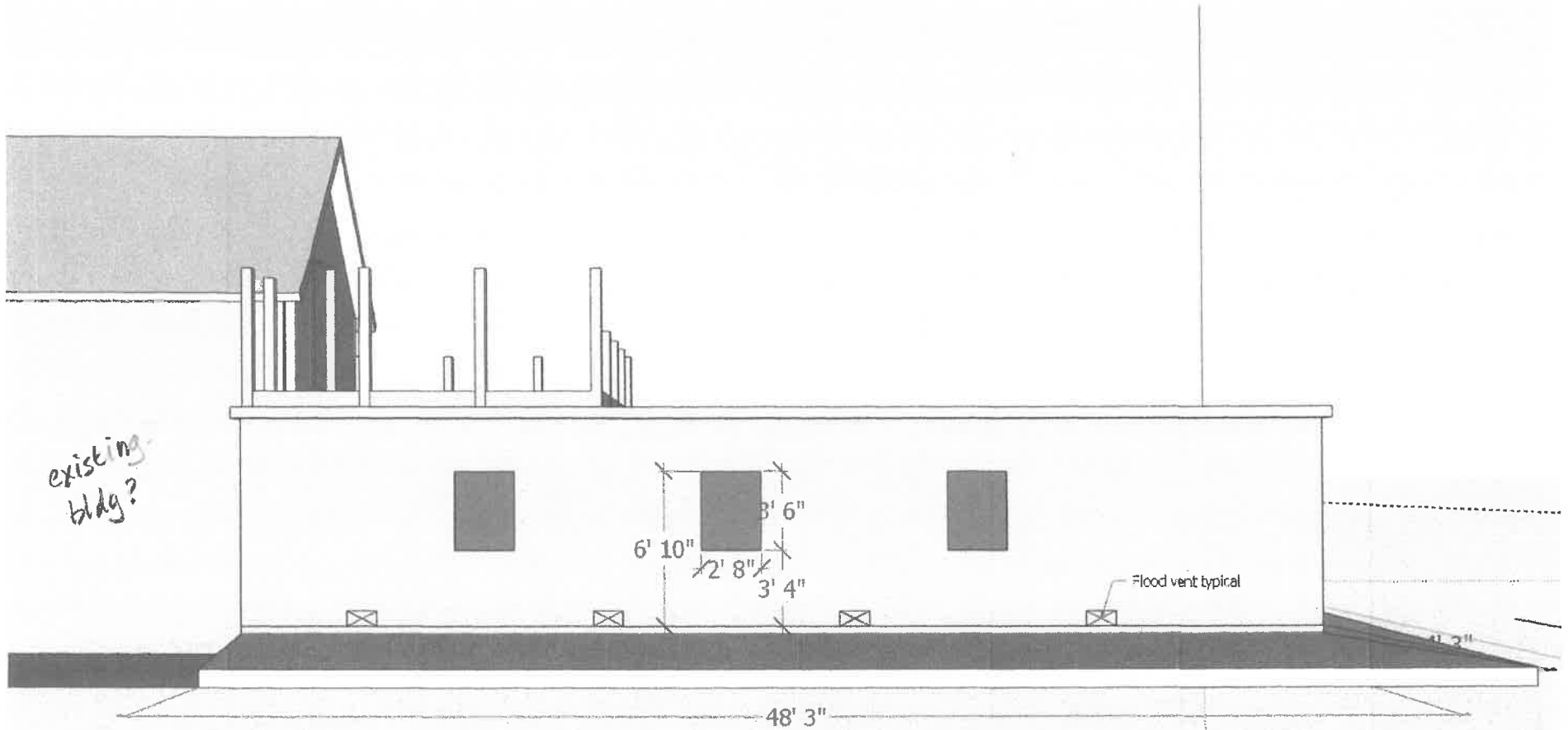

EXHIBIT C2

#009-21 #09620
 SIMON SIMON
 2/26/21 8/20/20

WEST (facing 3 Healy Crt.)



existing
bldg?

Flood vent typical

48' 3"

EXHIBIT C3

NORTH (facing 141 S. Main St.)

#009-21	#096-20
SIMON	SIMON
2/26/21	8/20/20

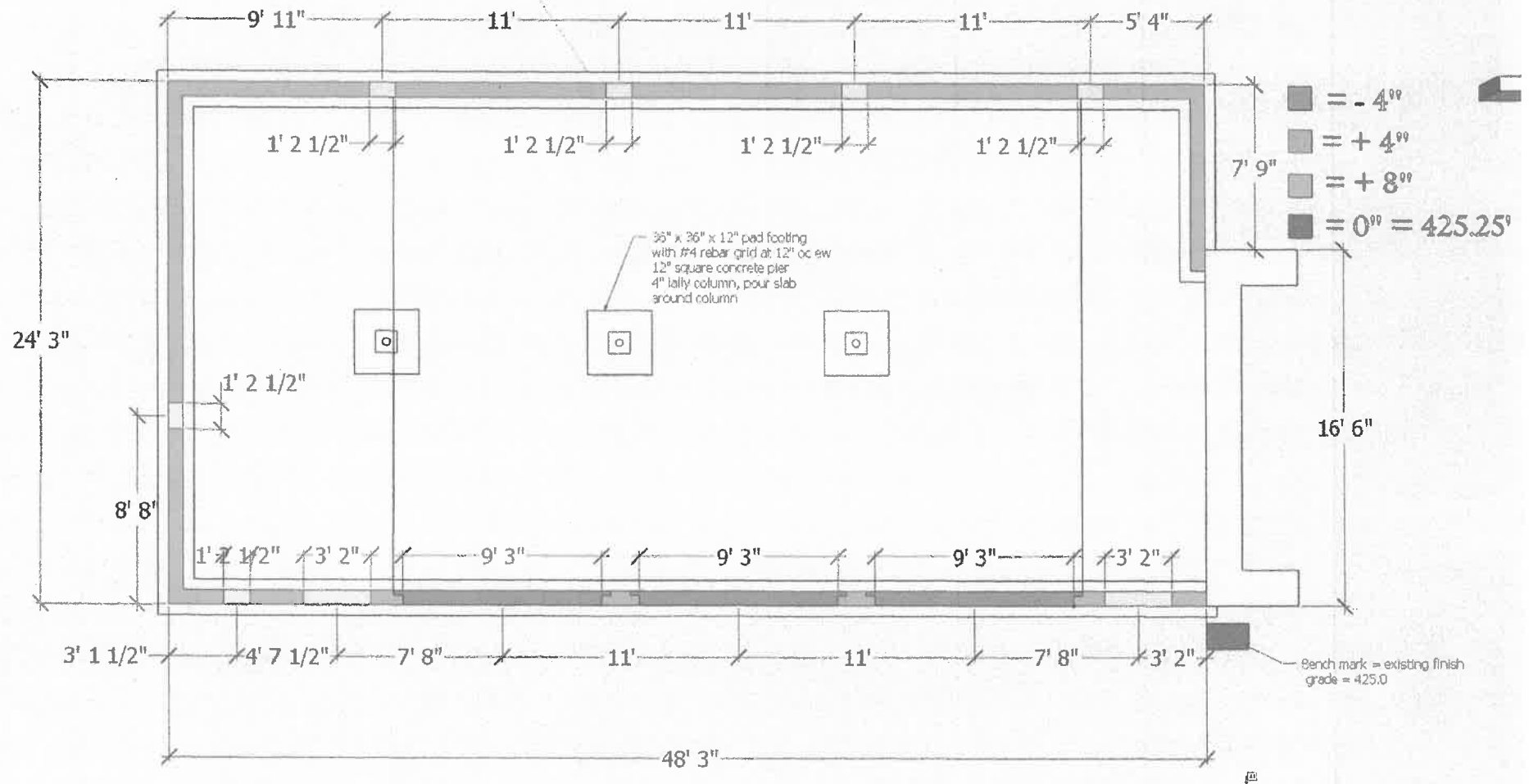

FND. PLAN

EXHIBIT D1

#009-21
SIMON
2/26/21

#096-20
SIMON
8/20/20

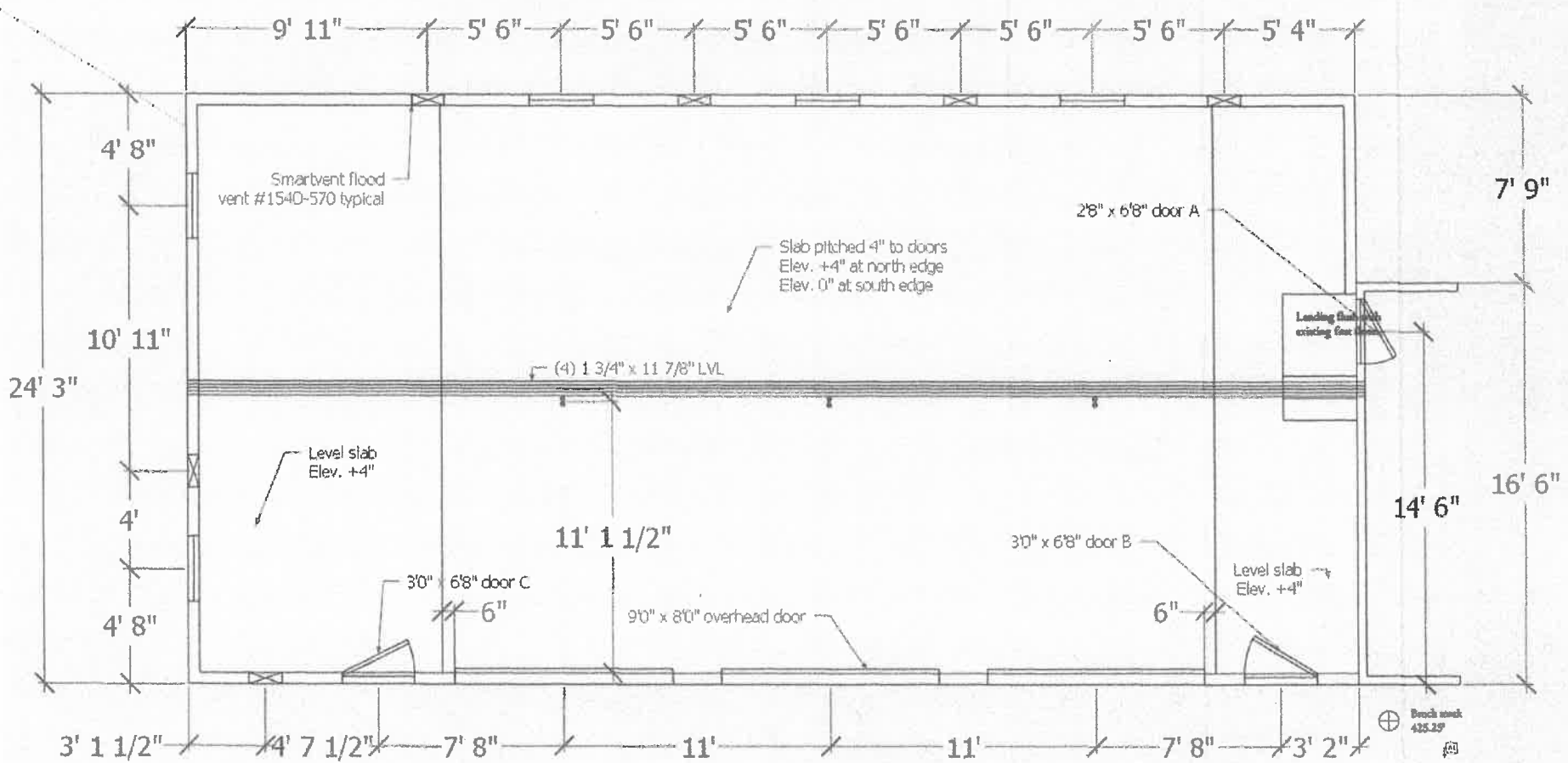

EXHIBIT D2

#009-21 #096-20
 SIMON SIMON
 2/26/21 8/20/20

1st FUR. FRAMING

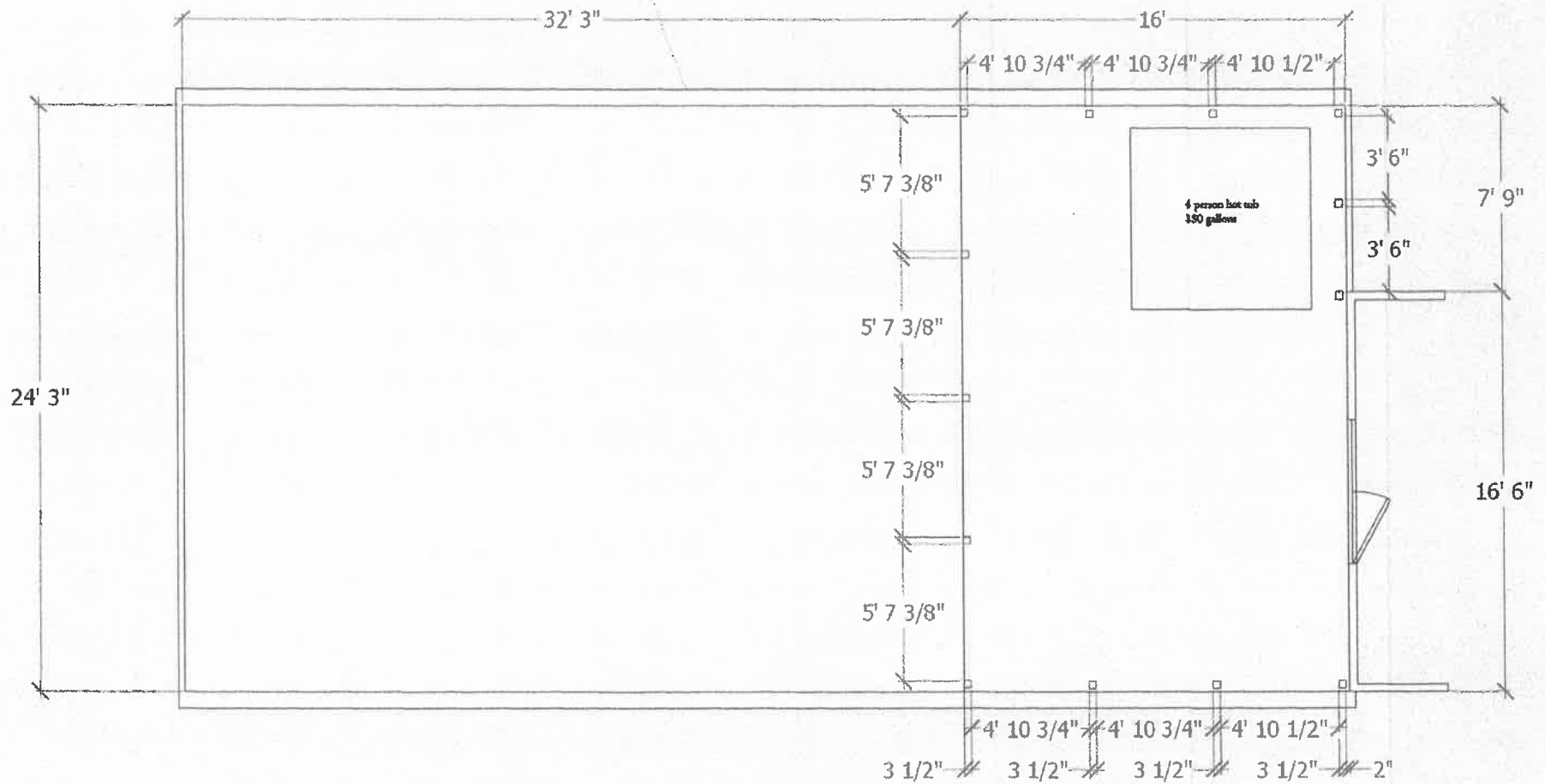
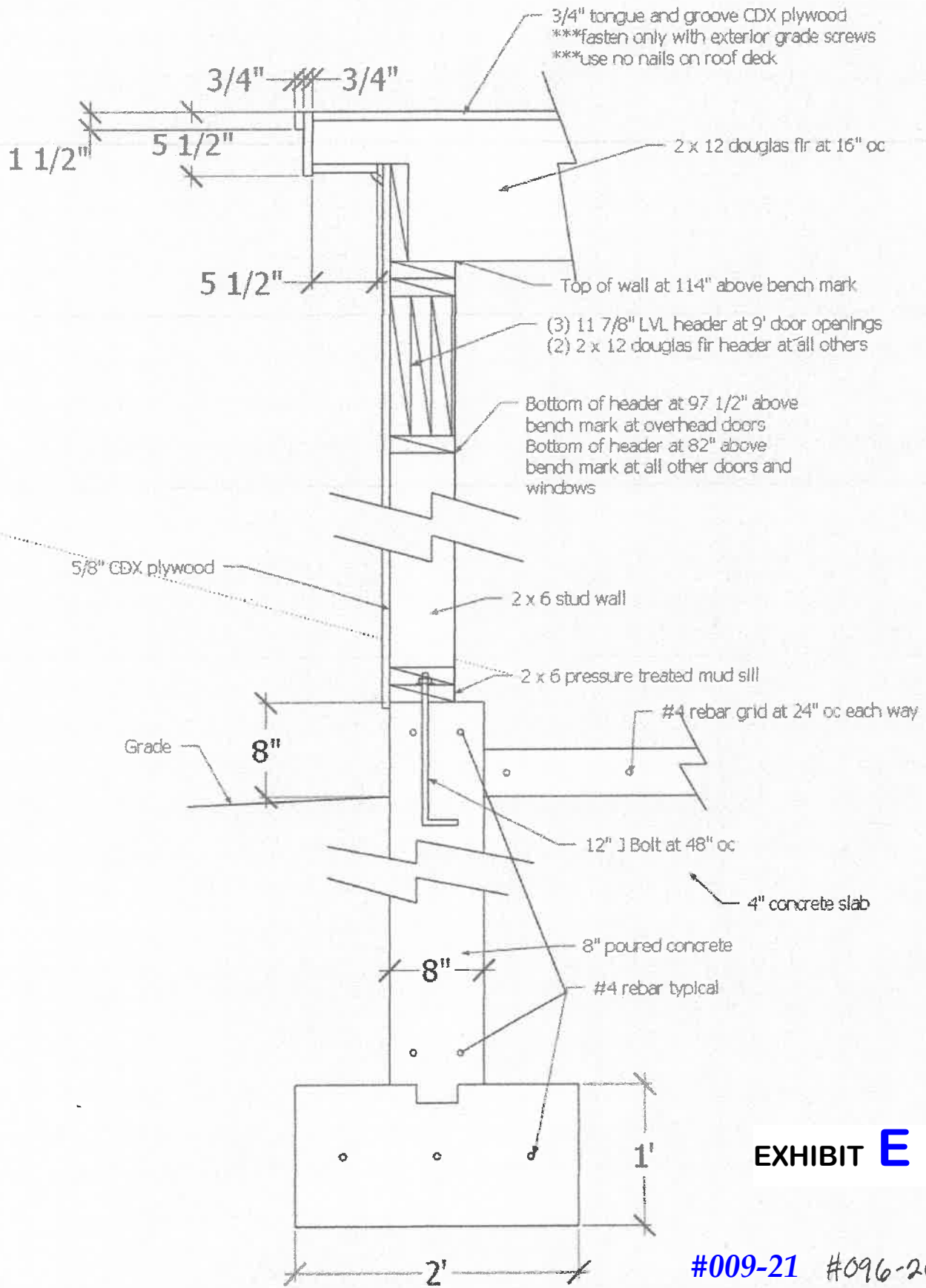

EXHIBIT D3

#009-21	#096-20
SIMON	SIMON
2/26/21	8/20/20

NOSE/DECK



SECTION

EXHIBIT E

#009-21 #096-20
 SIMON SIMON
 2/26/21 8/20/20

DUAL FUNCTION SERIES

This series of vents offers certified flood venting protection with superior automatic natural ventilation control. Ideal for crawlspace applications and other areas requiring flood venting protection as well as natural air ventilation.

VENTILATION

A bimetal coil automatically opens and closes the ventilation louvers as temperature changes from 35° F to 75° F.

No electricity is required.

In the event of a flood, the internal floats lift to release the flood door to rotate open and relieve the hydrostatic pressure regardless of the louvers' position, open or closed.

1 Smart Vent
1540-510

2 Stacker
1540-511

Stacker Models are twice as efficient as a single unit and are a great solution for large amounts of square footage, and in situations where there is not enough wall space to fit in the necessary or required single units.

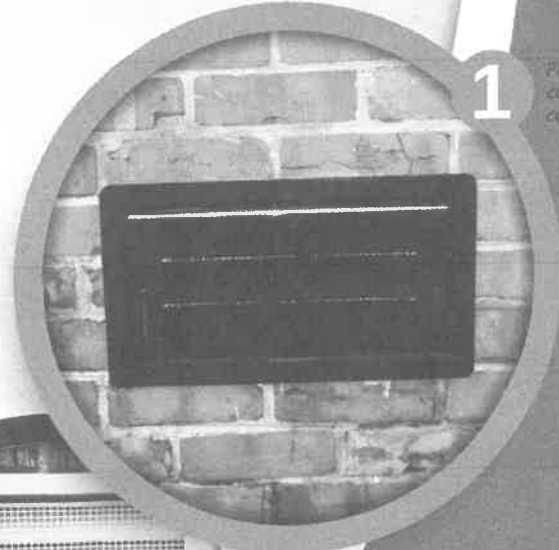
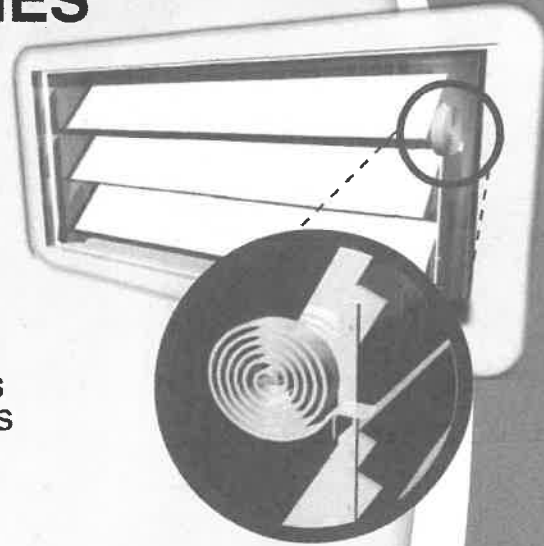

1 Pictured in custom powder coat black

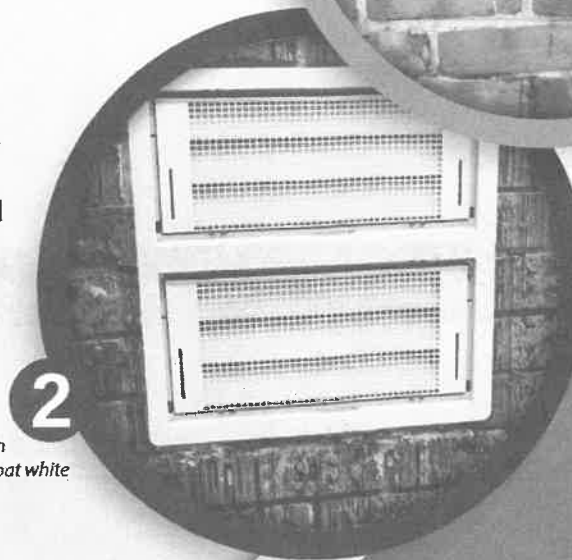

2 Pictured in powder coat white

#009-21
SIMON
2/26/21

For more information on Flood Protection Solutions, contact:

Smart Vent 430 Andbro Drive, Unit 1 • Pitman, NJ 08071
Website: www.smartvent.com Tel: (877) 441-8368 Email: info@smartvent.com

#096-20
SIMON
8/20/20

EXHIBIT F2

#009-21
SIMON
2/26/21

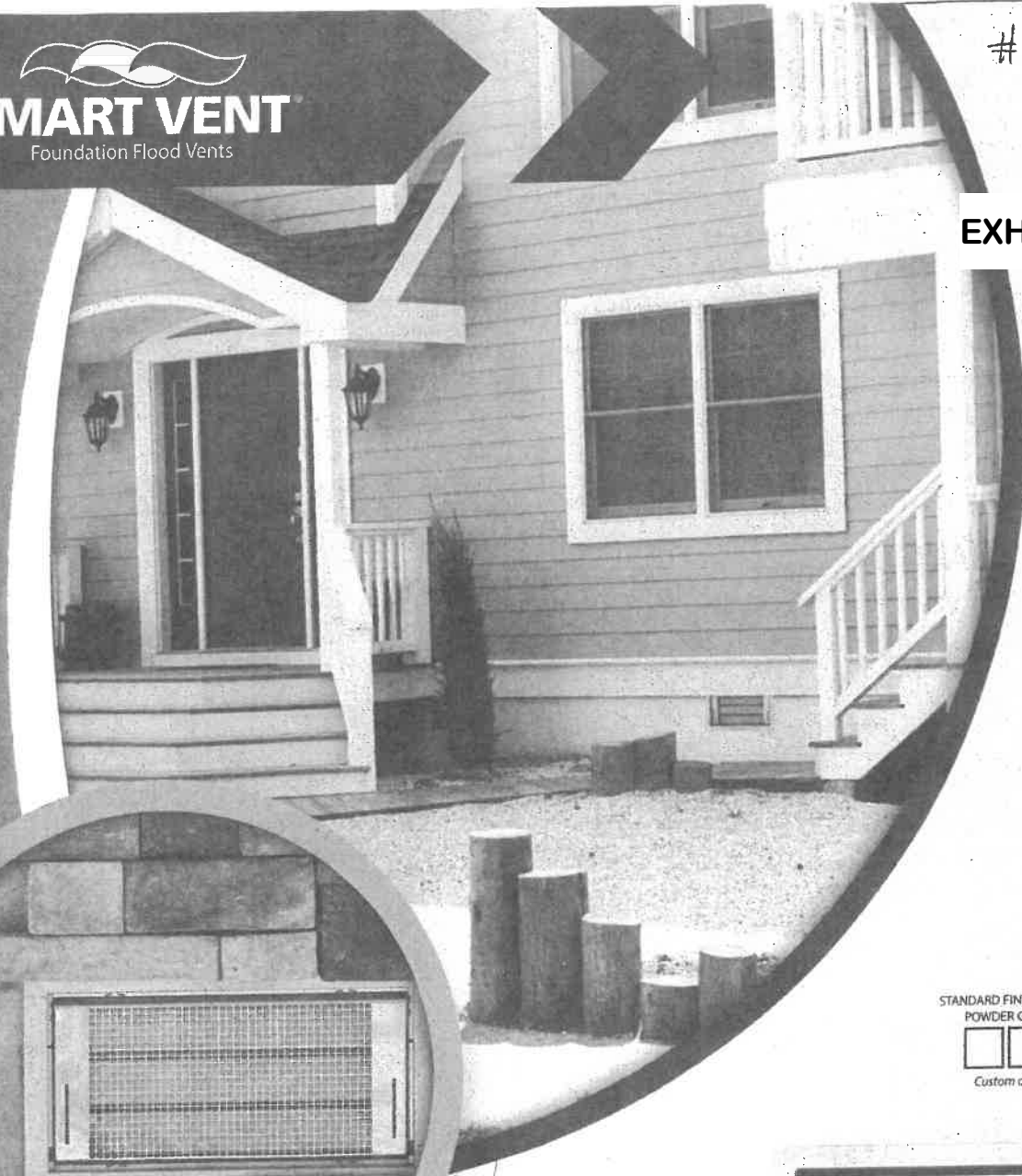

STANDARD FINISH POWDER COAT WHITE
POWDER COAT PAINT OPTIONS:

Custom colors also available.

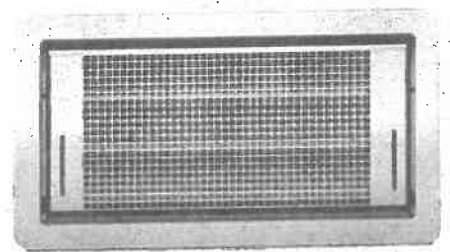

MODEL NUMBER	FLOOD COVERAGE	AIR VENTILATION	VENT SIZE	ROUGH OPENING
1540-510	200 sq. ft.	51 sq. in.	16" W x 8" H x 3" D	16 $\frac{1}{4}$ in x 8 $\frac{1}{4}$ in
1540-511	400 sq. ft.	102 sq. in.	16" W x 16" H x 3" D	16 $\frac{1}{4}$ in x 16 $\frac{3}{8}$ in

 To view other sizing options see Multi-frames

For more information on Flood Protection Solutions, contact:

Smart Vent 430 Andro Drive, Unit 1 - Pitman, NJ 08071
Website: www.smartvent.com Tel: (877) 441-8368 Email: info@smartvent.com

(2 of 2)

From: [Swanberg, Ned](#)
To: [Dina Bookmyer-Baker](#)
Subject: RE: 143 S. Main St, new gar-stg
Date: Friday, March 12, 2021 1:39:55 PM
Attachments: [image005.png](#)
[image001.png](#)

EXHIBIT G
#009-21 SIMON
2/26/21

Hello Dina, This looks to be workable under the flood regulations.

As a flood-vented structure it wouldn't displace floodwater so there would be no need for comp storage.

The number of smart vents should work. No more than 12" above grade. Probably better if a couple on the upstream/driveway side.

Flood damage resistant materials and methods below the DFE of 429.2' (BFE of 427.2' + 2)

I would also suggest as-built documentation or a post construction visit to confirm vent installation.

Please let me know if you would rather have a formal write up - otherwise I think this can go forward.

Best wishes,
Ned



Ned Swanberg, CFM | Regional Floodplain Manager (he/ki)
Vermont Agency of Natural Resources | Department of Environmental Conservation
Watershed Management | Rivers
1 National Life Dr. | Davis 2 | Montpelier, VT 05620-3522
802-490-6160
www.floodready.vt.gov
www.floodtraining.vt.gov
bit.ly/flood-manager
anr.vermont.gov

Due to the coronavirus (COVID-19), the Agency of Natural Resources is taking additional safety measures to protect our employees, partners and customers. We anticipate we will be working remotely until at least March 31, 2021 and encourage you to communicate electronically or via phone to the greatest extent possible. Thank you for your patience and understanding that responses may occasionally be delayed.

From: Dina Bookmyer-Baker <dbookmyerbaker@waterburyvt.com>
Sent: Friday, March 12, 2021 12:30 PM
To: Swanberg, Ned <Ned.Swanberg@vermont.gov>
Subject: 143 S. Main St, new gar-stg

EXTERNAL SENDER: Do not open attachments or click on links unless you recognize and trust the sender.

Hi Ned,

Please see the attached application for a new structure at 143 S. Main Street. You looked at an earlier version of this last year at the end of February (2/24 - 2/25/20). That project was withdrawn in September 2020.

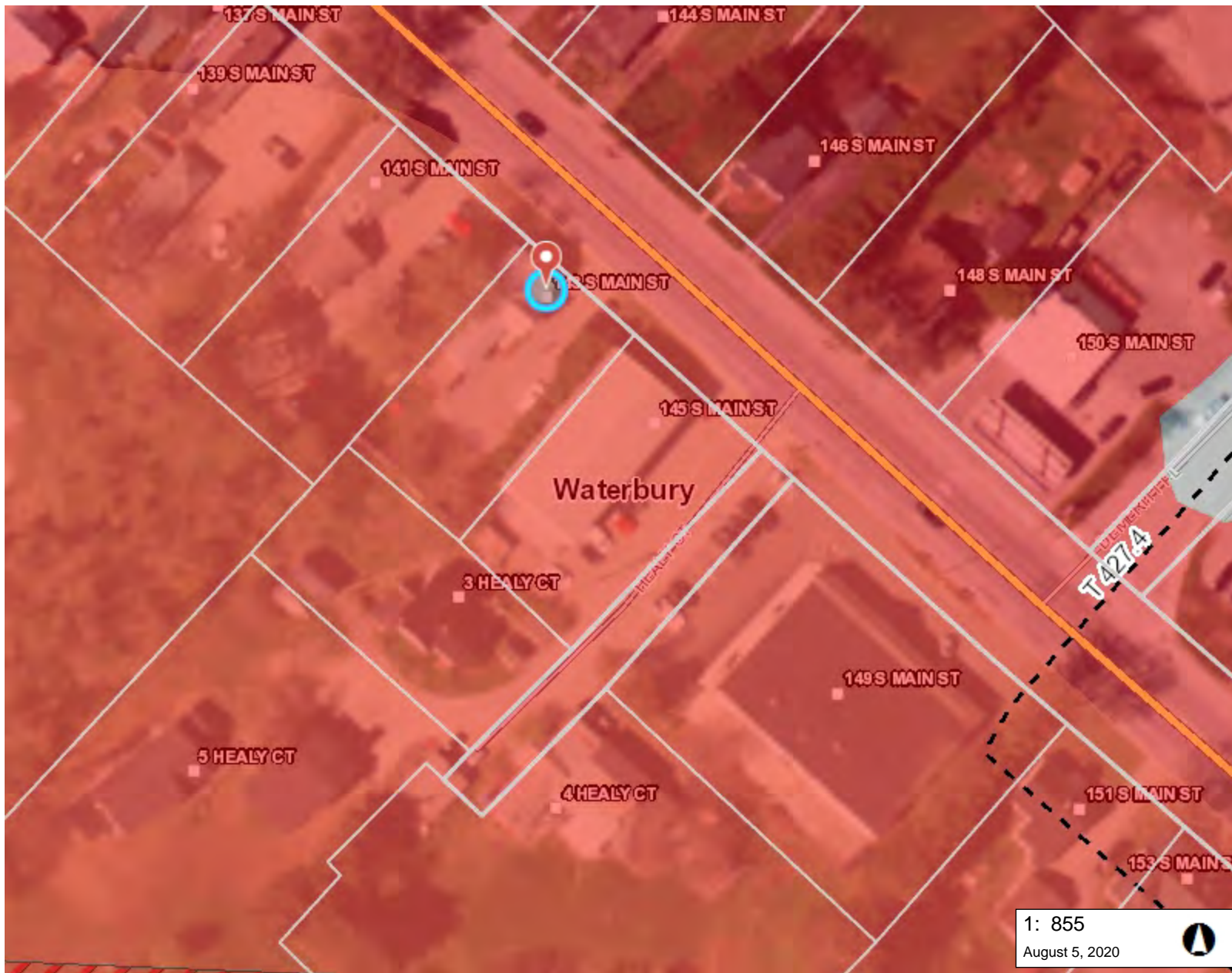

LEGEND

- Parcel lines**
 - Right-of-way boundary
 - Surface water boundary
 - Parcel boundary
 - Disputed parcel boundary
- Parcels (standardized)**
- Inactive parcels**
- Parcel easements**
- Parcels (non-standardized)**
- DFIRM X-Sections**
- DFIRM Floodways**
- Flood Hazard Areas (Only FEM)**
 - AE (1-percent annual chance flood)
 - A (1-percent annual chance floodpl)
 - AO (1-percent annual chance zone feet)
 - 0.2-percent annual chance flood ha
- Buildings (E911)**
- Roads**
 - Interstate
 - Principal Arterial
 - Minor Arterial
 - Major Collector
 - Minor Collector
 - Local
 - Not part of function Classification S
- Stream**
- Town Boundary**

1: 855
August 5, 2020

43.0 0 22.00 43.0 Meters

WGS_1984_Web_Mercator_Auxiliary_Sphere 1" = 71 Ft. 1cm = 9 Meters

© Vermont Agency of Natural Resources THIS MAP IS NOT TO BE USED FOR NAVIGATION

DISCLAIMER: This map is for general reference only. Data layers that appear on this map may or may not be accurate, current, or otherwise reliable. ANR and the State of Vermont make no representations of any kind, including but not limited to, the warranties of merchantability, or fitness for a particular use, nor are any such warranties to be implied with respect to the data on this map.

NOTES

Map created using ANR's Flood Ready Map

#009-21 SIMON



143 So. Main St.

Waterbury, VT

1 inch = 30 Feet



June 6, 2019

(Staff)



www.cai-tech.com

#009-21 SIMON



Data shown on this map is provided for planning and informational purposes only. The municipality and CAI Technologies are not responsible for any use for other purposes or misuse or misrepresentation of this map.

NOTICE OF PUBLIC HEARING
WATERBURY DEVELOPMENT REVIEW BOARD
Wednesday, April 7, 2021

Date mailed certified: 3/22/21

FROM: Lane Simon
143 S. Main Street
Waterbury, VT 05676

TO: Adjoining Landowners

Adjoining landowners are hereby notified: The Waterbury Development Review Board will convene a Public Hearing at **6:30 p.m. on Wednesday, April 7, 2021, via ZOOM and conference call. Connection details will be provided on the DRB agenda published on www.waterburyvt.com prior to the meeting.** The Board will act on the following:

#009-21: Lane Simon (applicant), Phyllis Simon (owner)
Setback waiver, Variance, and Special Flood Hazard Area review to construct an attached 3-bay garage/roof-deck in the setback that exceeds the maximum lot coverage at 143 South Main Street. (VMR/SFHA zoning and overlay districts)

This notice is being sent to you as an adjacent property owner to the project described above. You should receive this notice not less than 15 days prior to the date of the public hearing above.

Although you are not required to attend this hearing, your participation in the local regulatory proceeding is a prerequisite to the right to appeal any resulting decision or action of the Development Review Board, as set forth in 24 V.S.A. § 4471. Participation in a local regulatory proceeding shall consist of offering, through oral or written testimony, evidence or a statement of concern related to the subject of the proceeding.

This application and all supporting materials are on file at the Waterbury Municipal Offices. Please call or email the Zoning Administrator, Dina Bookmyer-Baker, at 802-244-1018 or dbookmyerbaker@waterburyvt.com to make arrangements to review the file. The municipal offices are currently closed to the public except by appointment only.

7019 0700 0000 2855 0532

**U.S. Postal Service™
CERTIFIED MAIL® RECEIPT**
Domestic Mail Only

For delivery information, visit our website at www.usps.com®.

Waterbury, VT 05676

OFFICIAL USE

Certified Mail Fee	\$3.60
Extra Services & Fees (check box, add fee as appropriate)	\$0.00
<input type="checkbox"/> Return Receipt (hardcopy)	\$0.00
<input type="checkbox"/> Return Receipt (electronic)	\$0.00
<input type="checkbox"/> Certified Mail Restricted Delivery	\$0.00
<input type="checkbox"/> Adult Signature Required	\$0.00
<input type="checkbox"/> Adult Signature Restricted Delivery	\$0.00
Postage	\$0.55
Total Postage and Fees	\$4.15

Postmark Here
MAR 22 2021

Sent To
Robert + Kathryn Grace
144 South Main St.
Waterbury, VT 05676

PS Form 3800, April 2015 PSN 7530-02-000-9047 See Reverse for Instructions

7019 0700 0000 2855 0525

**U.S. Postal Service™
CERTIFIED MAIL® RECEIPT**
Domestic Mail Only

For delivery information, visit our website at www.usps.com®.

South Burlington, VT 05403

OFFICIAL USE

Certified Mail Fee	\$3.60
Extra Services & Fees (check box, add fee as appropriate)	\$0.00
<input type="checkbox"/> Return Receipt (hardcopy)	\$0.00
<input type="checkbox"/> Return Receipt (electronic)	\$0.00
<input type="checkbox"/> Certified Mail Restricted Delivery	\$0.00
<input type="checkbox"/> Adult Signature Required	\$0.00
<input type="checkbox"/> Adult Signature Restricted Delivery	\$0.00
Postage	\$0.55
Total Postage and Fees	\$4.15

Postmark Here
MAR 22 2021

Sent To
EQUUS LLC
116 1/2 Williston Rd
S. Burlington, VT 05403

PS Form 3800, April 2015 PSN 7530-02-000-9047 See Reverse for Instructions

7019 0700 0000 2854 9468

**U.S. Postal Service™
CERTIFIED MAIL® RECEIPT**
Domestic Mail Only

For delivery information, visit our website at www.usps.com®.

Waterbury, VT 05676

OFFICIAL USE

Certified Mail Fee	\$3.60
Extra Services & Fees (check box, add fee as appropriate)	\$0.00
<input type="checkbox"/> Return Receipt (hardcopy)	\$0.00
<input type="checkbox"/> Return Receipt (electronic)	\$0.00
<input type="checkbox"/> Certified Mail Restricted Delivery	\$0.00
<input type="checkbox"/> Adult Signature Required	\$0.00
<input type="checkbox"/> Adult Signature Restricted Delivery	\$0.00
Postage	\$0.55
Total Postage and Fees	\$4.15

Postmark Here
MAR 22 2021

Sent To
Howard + Georgia Rexford
146 South Main St.
Waterbury, VT 05676

PS Form 3800, April 2015 PSN 7530-02-000-9047 See Reverse for Instructions

7019 0700 0000 2854 9451

**U.S. Postal Service™
CERTIFIED MAIL® RECEIPT**
Domestic Mail Only

For delivery information, visit our website at www.usps.com®.

Georgetown, FL 32139

OFFICIAL USE

Certified Mail Fee	\$3.60
Extra Services & Fees (check box, add fee as appropriate)	\$0.00
<input type="checkbox"/> Return Receipt (hardcopy)	\$0.00
<input type="checkbox"/> Return Receipt (electronic)	\$0.00
<input type="checkbox"/> Certified Mail Restricted Delivery	\$0.00
<input type="checkbox"/> Adult Signature Required	\$0.00
<input type="checkbox"/> Adult Signature Restricted Delivery	\$0.00
Postage	\$0.55
Total Postage and Fees	\$4.15

Postmark Here
MAR 22 2021

Sent To
Richard Wilbur
P.O. Box 636
Georgetown, FL 32139-0636

PS Form 3800, April 2015 PSN 7530-02-000-9047 See Reverse for Instructions

7019 0700 0000 2854 9444

**U.S. Postal Service™
CERTIFIED MAIL® RECEIPT**
Domestic Mail Only

For delivery information, visit our website at www.usps.com®.

Waterbury, VT 05676

OFFICIAL USE

Certified Mail Fee	\$3.60
Extra Services & Fees (check box, add fee as appropriate)	\$0.00
<input type="checkbox"/> Return Receipt (hardcopy)	\$0.00
<input type="checkbox"/> Return Receipt (electronic)	\$0.00
<input type="checkbox"/> Certified Mail Restricted Delivery	\$0.00
<input type="checkbox"/> Adult Signature Required	\$0.00
<input type="checkbox"/> Adult Signature Restricted Delivery	\$0.00
Postage	\$0.55
Total Postage and Fees	\$4.15

Postmark Here
MAR 22 2021

Sent To
John McCannell
3 Healy Court
Waterbury, VT 05676

PS Form 3800, April 2015 PSN 7530-02-000-9047 See Reverse for Instructions

EXHIBIT I
#009-21 SIMON